

Pressure gauge

Recommended for visual inspection of the lubrication systems performance and future troubleshooting.

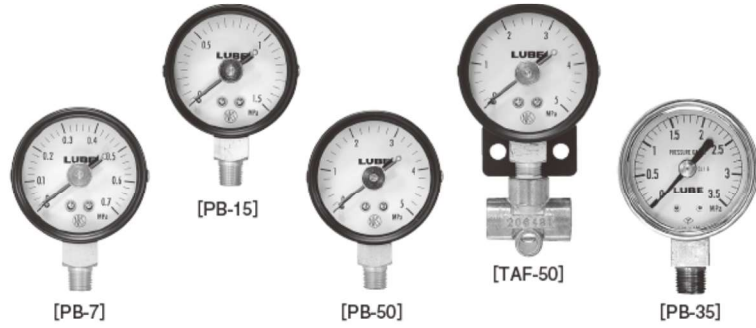

Specifications

Accuracy	±3%F.S
Temperature range	15°C~40°C
Material	Bourdon tube C6872T (Min.10MPa C5191T) Frame SPCC steel plate

Model

Pressure gauge

Model	Part Number	Pressure range (MPa)	Connection	Installation pin
PB-7	109166	0.7	R1/8	Available
PB-15	109167	1.5		
PB-50	109161	5		
PB-50B	109162	5	M8×1	—
TAF-7	109154	0.7		
TAF-15	109155	1.5		
TAF-50	209117	5	M10×1	Available
* PB-35	209136	3.5	R1/8	Not available
* PB-35B	209137			

Pressure gauge fitting plate

Model	Part Number
PP	109102

* Not usable for PB-35 and PB-35B

Directions for use

- Use care not to drop or exert other strong impact.
- Do not apply pressure beyond specified range.

Dimensional drawing

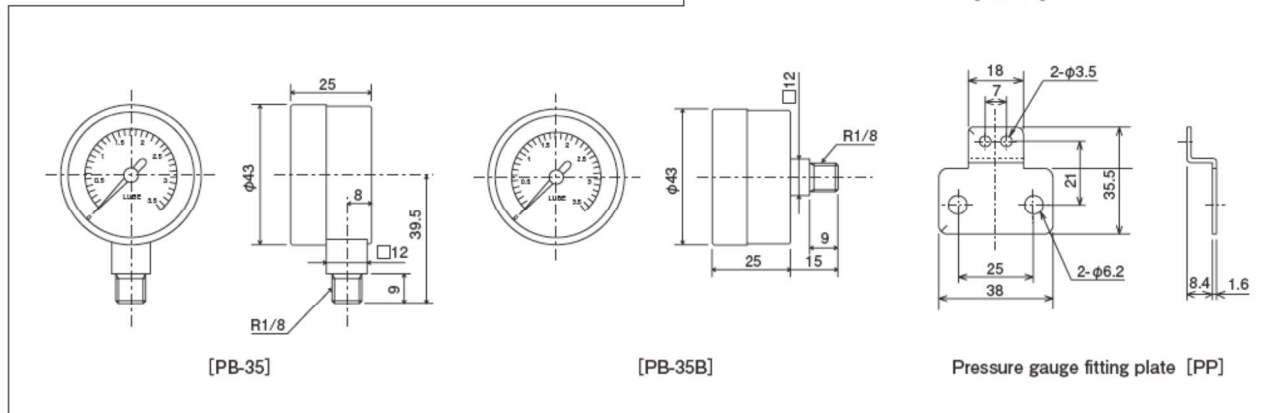
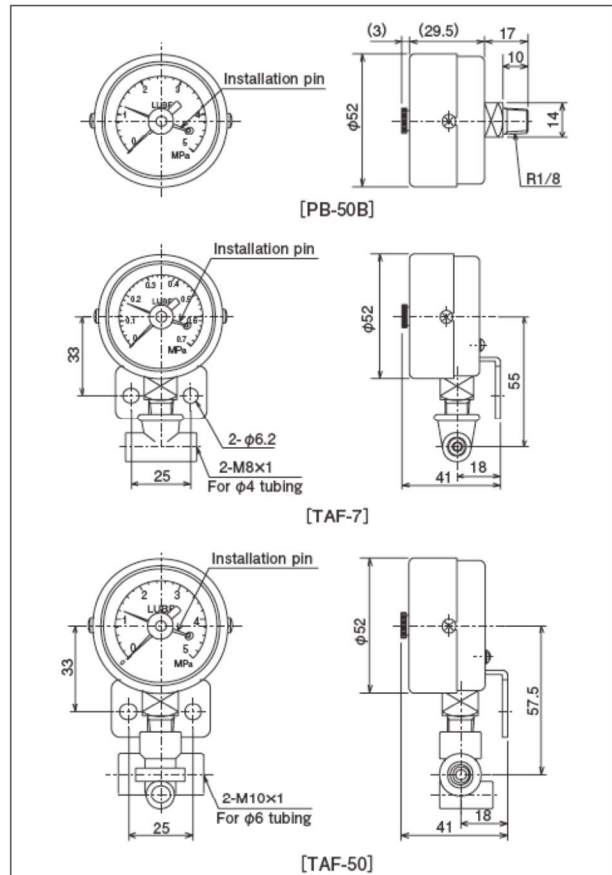

Accessories