

Metering valve for grease with clogged line detection

MGI

MGI valves are Positive Displacement Injectors with clogging indication. When there is a clogging issue, the red pin pops out for visual indication of a problem.



[JV-4S-MGI-10-10]

Specifications

Operating pressure	1.5MPa
Reset pressure	0.5MPa
Detection pin operating pressure	1.5MPa

※ Material: Brass

Model

Model	Part Number	Discharge volume (mL)	L (mm)	Mark
MGI-3	205174	0.03	66.5	3
MGI-5	205175	0.05		5
MGI-10	205176	0.1		10
MGI-20	205177	0.2	74	20
MGI-30	205178	0.3		30
MGI-50	205182	0.5		50

Dimensional drawing

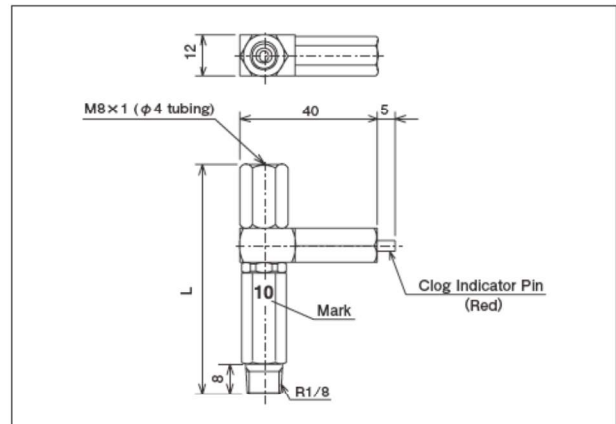

Directions for use

- When installing the valve on a junction side, screw it into place with a wrench applied to the valve body.
- When connecting the valve to piping, turn bushing holding nipple with a wrench.

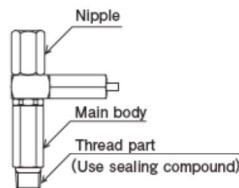

● Related parts

EGM-10S-4-7C : P.47	EGH-3P : P.49	EGH-4C : P.49	JV Junction : P.63	Pressure gauge : P.85	Main tubing : P.171	Branch tubing : P.171	Adapter assemblies : P.185
Compression parts : P.169	Adapters : P.175						